

HEADHUNTER

SPARE TIRE BRACKET INSTALLATION GUIDE

DOSE

SPARE TIRE BRACKET

COMPATIBLE WITH CLASSIC, PRO, AND ARROW TRAILERS

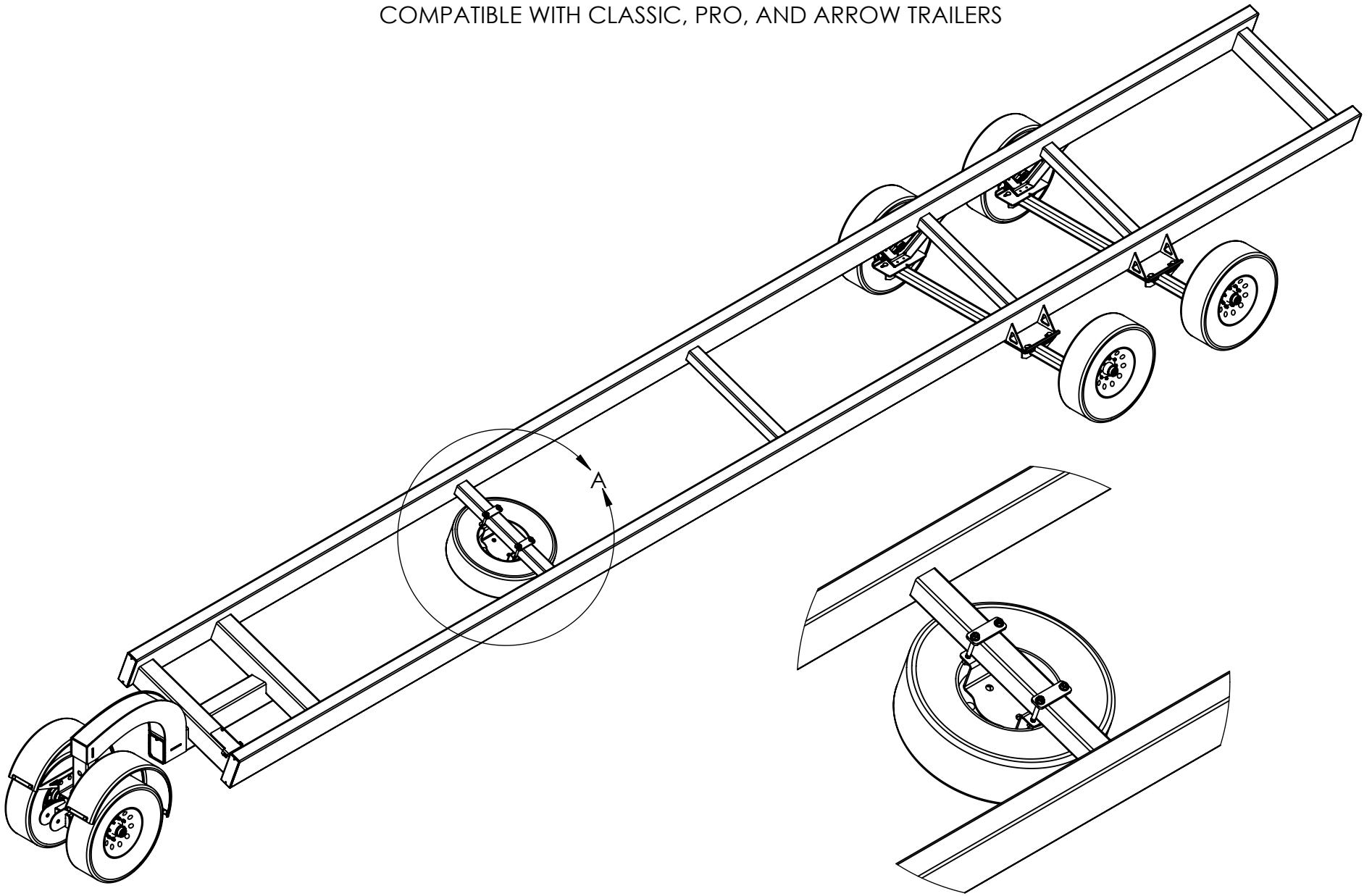

DETAIL A

NOTES:

1. SOME COMPONENTS REMOVED FOR CLARITY.
2. MOUNTING POSITIONS ARE FOR REFERENCE ONLY;
ADJUST AS NEEDED.



SPARE TIRE BRACKET

NOTE: TIRE NOT INCLUDED

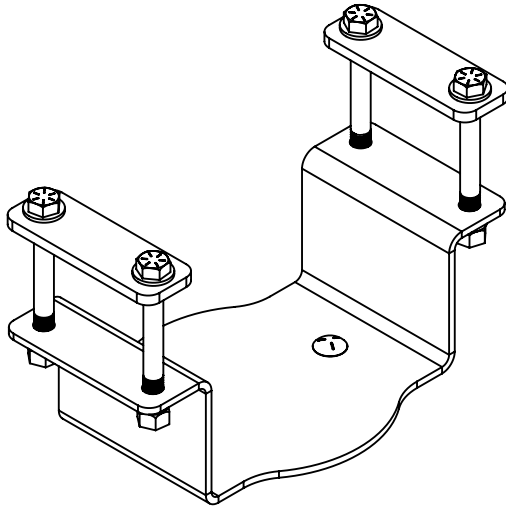

PART NUMBER:
87-080900

10" and 12" FRAME
4" CROSSMEMBER

COMPATIBILITY:

CLASSIC: 24', 32', 38', and 43'
ARROW: 24', 31', 37', and 42'

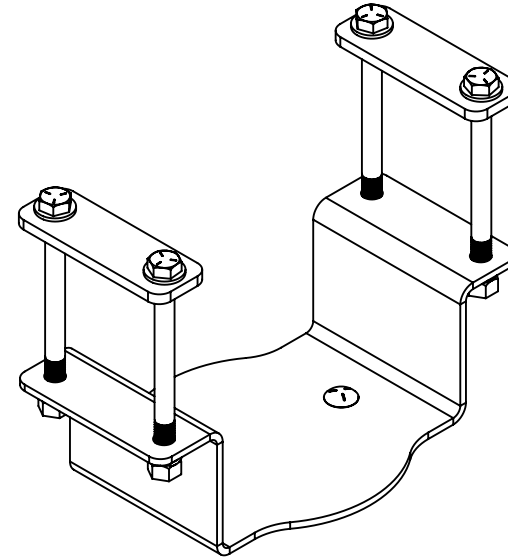

PART NUMBER:
87-080950

14" FRAME
6" CROSSMEMBER

COMPATIBILITY:

CLASSIC: 43'-14, 48', and 53'
PRO: 32', 38', 43', 48', and 53'

HEADHUNTER

MOUNTING INSTRUCTIONS

TOOLS NEEDED:

15/16" Socket
15/16" Wrench
13/16" Socket
1/2" Impact gun or Ratchet
Tape Measure

Estimated Install Time

 ≈ 30 min

(NOTE: REFERENCE THE CIRCLED PART NUMBERS ON THE FOLLOWING PAGES 4 AND 5.)

STEPS:

1. Remove the 5/8" bolts (3), washers (4) (5), and nuts (6) from the mounting bracket (1) and strap (2).
2. Position the mounting bracket (1) and strap (2) in the middle of the frontmost cross member facing down.
-If placed incorrectly, clearance issues may occur with the header.
3. Referencing the exploded view on the next page, loosely assemble the 5/8" hardware around the crossmember in the order shown.
4. Using a tape measure, center the bracket (1) on the cross member.
5. Tighten hardware after centering.
6. Remove the 1/2" bolts (7), washers (8), and nuts (9) from the mounting bracket (1).
7. Align the tire rim holes to match the bolt holes on the bracket (1).
8. Referencing the exploded view on the next page, loosely assemble the 1/2" hardware through the tire rim and bracket (1).
9. Tighten hardware to complete.

If you have questions, call Ben Sommers at 515.601.6521

10" and 12" SPARE TIRE BRACKET ASSEMBLY

ITEM NO.	PART NUMBER	DESCRIPTION	QTY.
1	27-080902	WHEEL MOUNTING STRAP	2
2	02-5811512HHCSZP	5/8"-11 x 5 1/2" HEX HEAD CAP SCREW	4
3	02-58WZP	5/8" WASHER, ZINC PLATED	8
4	02-58LW	5/8" LOCK WASHER	4
5	02-5811N	5/8"-11 CRIMP LOCK NUT	4
6	02-1220112CBGR5	1/2"-20 x 1 1/2" CARRIAGE BOLT, GRADE 5	2
7	02-9299	1/2" INTERNAL TOOTH LOCK WASHER	2
8	02-1220112LN	1/2"-20 LUG NUT	2
9	37-080901	BRACKET, WHEEL MOUNTING	1

4" CROSSMEMBER ON TRAILER

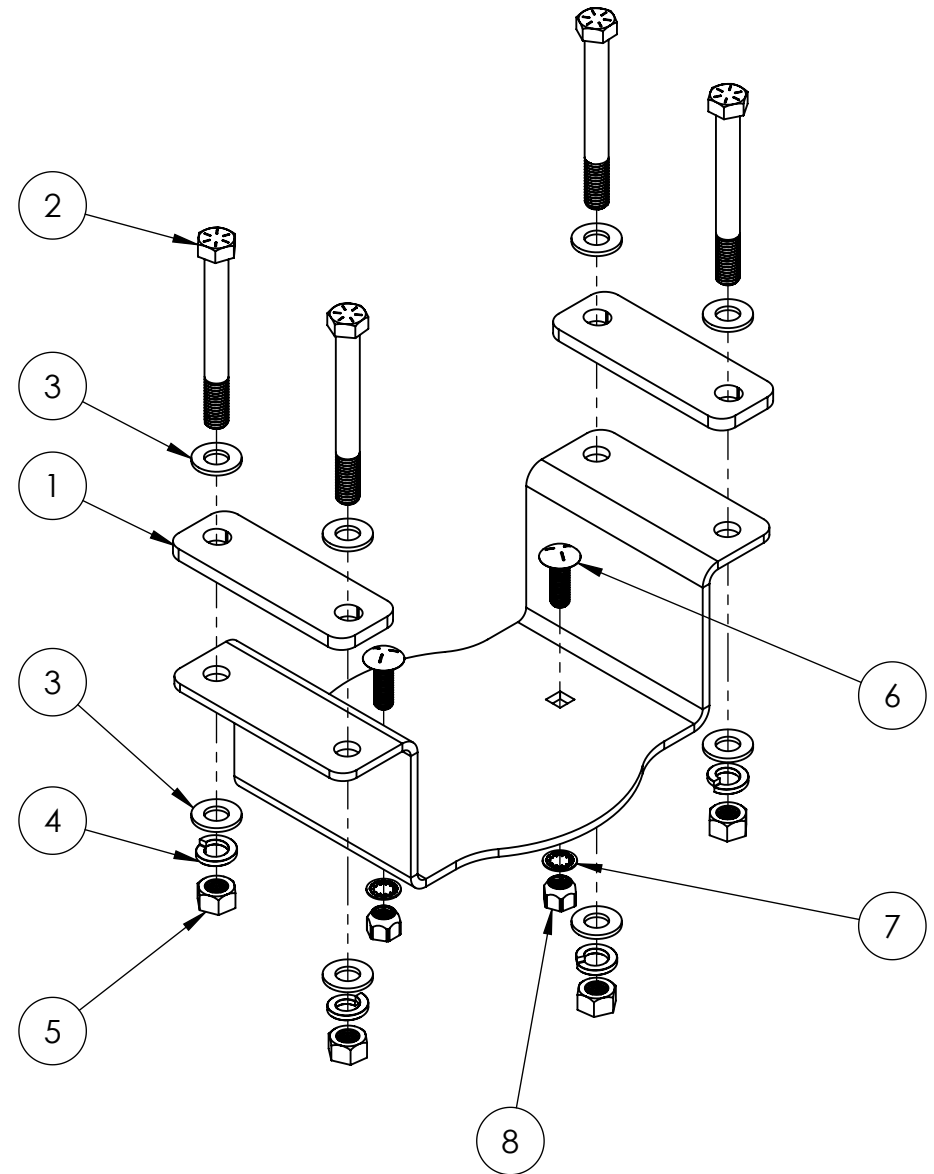
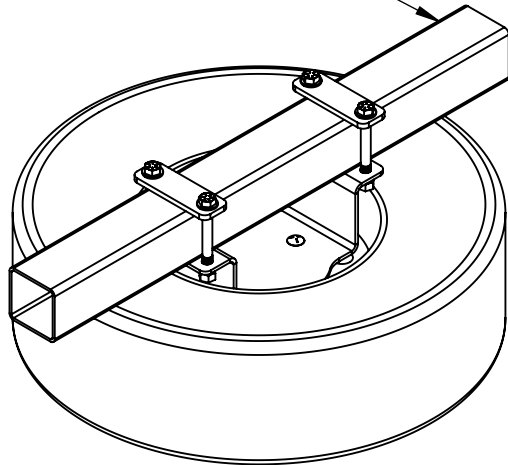

NOTES:

1. SOME COMPONENTS REMOVED FOR CLARITY.
2. MOUNT POSITIONS ARE FOR REFERENCE ONLY;
ADJUST AS NEEDED.
3. TIRE NOT INCLUDED.



14" SPARE TIRE BRACKET ASSEMBLY

ITEM NO.	PART NUMBER	DESCRIPTION	QTY.
1	27-080902	WHEEL MOUNTING STRAP	2
2	02-5811712HHCSZP	5/8"-11 x 7 1/2" HEX HEAD CAP SCREW	4
3	02-58WZP	5/8" WASHER, ZINC PLATED	8
4	02-58LW	5/8" LOCK WASHER	4
5	02-5811N	5/8"-11 CRIMP LOCK NUT	4
6	02-1220112CBGR5	1/2"-20 x 1 1/2" CARRIAGE BOLT, GRADE 5	2
7	02-9299	1/2" INTERNAL TOOTH LOCK WASHER	2
8	02-1220112LN	1/2"-20 LUG NUT	2
9	37-080901	BRACKET, WHEEL MOUNTING	1

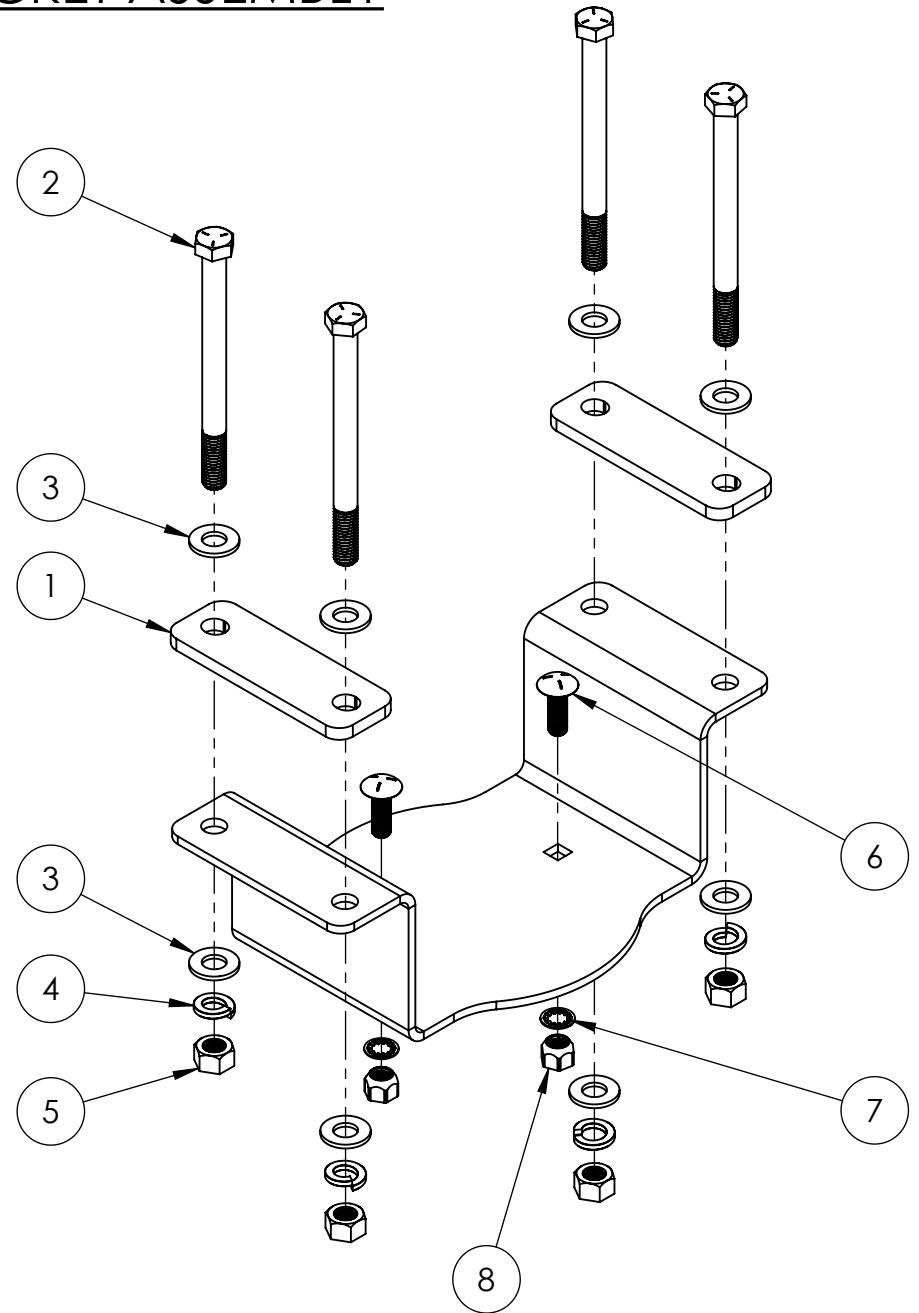
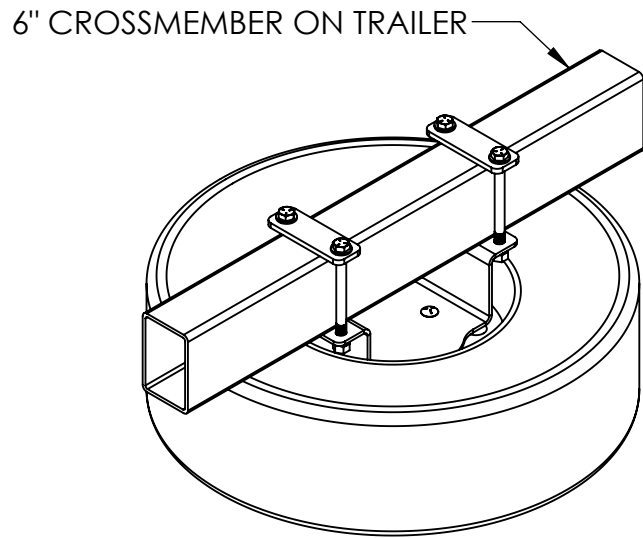

NOTES:

1. SOME COMPONENTS REMOVED FOR CLARITY.
2. MOUNT POSITIONS ARE FOR REFERENCE ONLY; ADJUST AS NEEDED.
3. TIRE NOT INCLUDED.

