

HEADHUNTER

TONGUE EXTENSION INSTALLATION GUIDE

COMPATIBLE WITH HEADHUNTER
CLASSIC, PRO, AND WARRIOR
TRAILERS



TONGUE PARTS

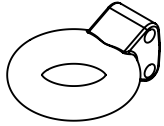

3" PINTLE EYE RING HITCH
02-16137

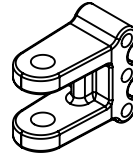

CLEVIS HITCH WITH 1" HOLE
02-07433800

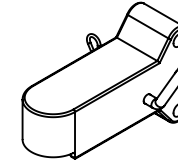

2 5/16" BALL COUPLER
02-AC20

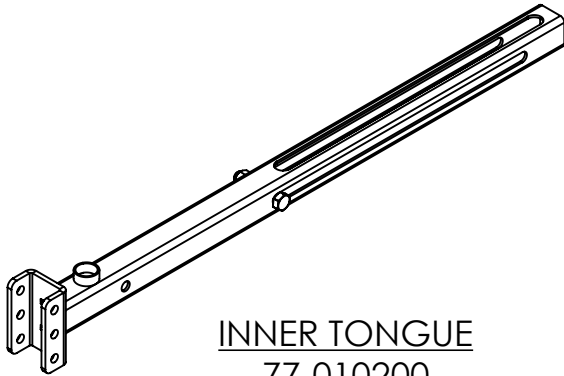

INNER TONGUE
77-010200

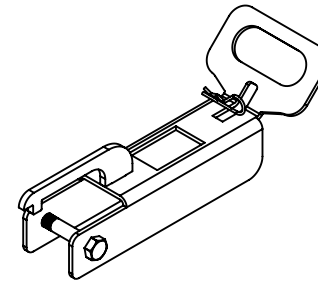

TONGUE HANDLE
77-010300

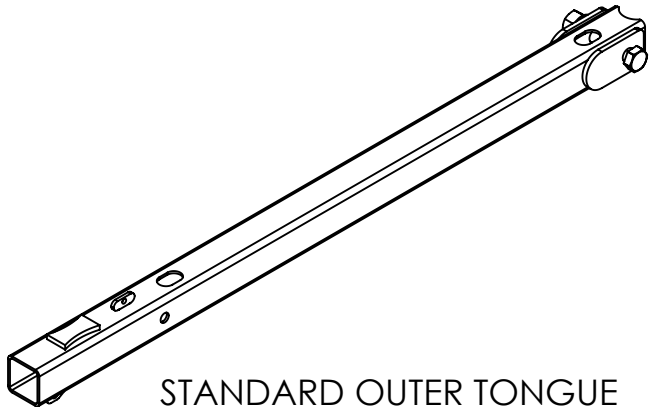

STANDARD OUTER TONGUE
77-010100

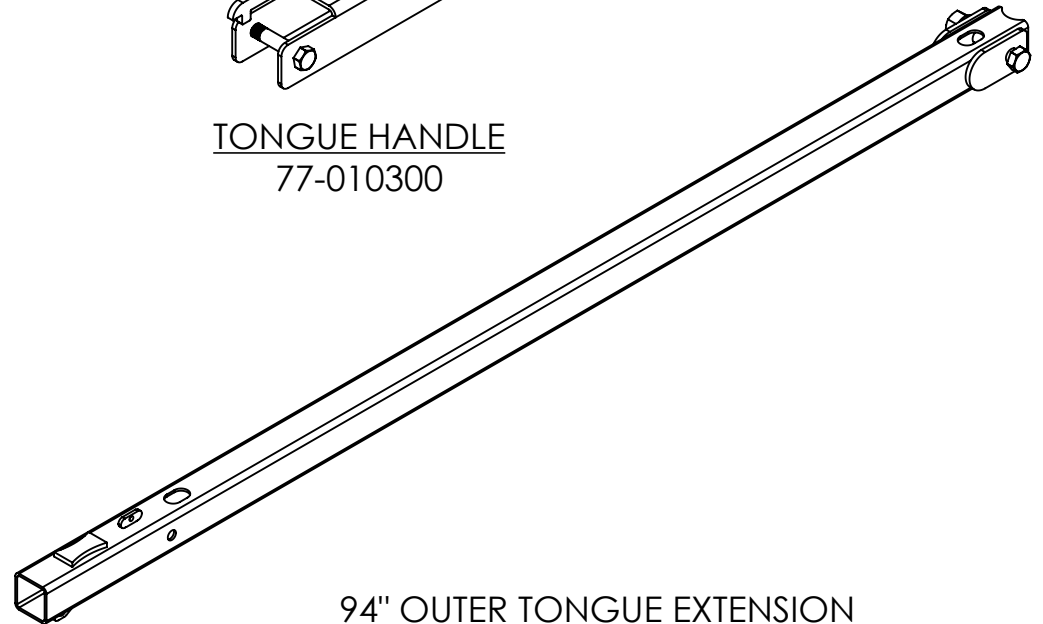

94" OUTER TONGUE EXTENSION
77-010400

NOTES:

1. ALL ASSEMBLIES COME WITH MOUNTING HARDWARE.



HEADHUNTER

TONGUE MOUNTING INSTRUCTIONS

TOOLS NEEDED:

1/2" IMPACT GUN OR RATCHET RIVET TOOL
1 1/2" SOCKET OR WRENCH HEAT SHRINK AND CRIMPING DEVICE
3/16" DRILL BIT AND DRILL WIRE STRIPPERS OR KNIFE

Estimated Install Time

 ≈ 30 min

ALL STEPS FOR THE RIVET DOOR ARE NOT APPLICABLE TO HEADHUNTER WARRIOR TRAILERS.
ALL STEPS FOR THE BRAKE BOX ARE NOT APPLICABLE IF YOUR TRAILER DOES NOT HAVE BRAKES.

STEPS:

(Reference pages 03-05 for step completion.)

1. Drill out the rivets on the drivers side rivet door and remove the door from trailer.
2. Disconnect the front wiring harness from the main harness.
3. Remove the bolt on the gooseneck front access door.
4. Noting which wires go where (take a picture), cut the brake box wires (black, white, blue).
5. To remove the front wiring harness, locate where it comes out at the gooseneck and remove from there.
 - Note: The 7-way plug does not allow the wiring harness to be removed from the tongue back towards the gooseneck.
6. Remove the 1" nut and bolt from the tongue assembly to remove it from the front axle.
7. Next, remove the 3/4" nut and bolt linking the inner tongue to the outer tongue.
8. Insert the inner tongue into the outer tongue extension and reinstall hardware from Step 8.
9. Feed the wiring harness through the new tongue assembly towards the gooseneck (the same way it was when it was removed).
10. Attach the tongue assembly to the front axle using the 1" nut and bolt from Step 7.
11. Next, the brake box wires will need to be rewired into the wiring harness.
12. Match the wires back to their previous configuration from Step 5.
 - Note: some wire casing may need stripped back to expose the wire.
13. Feed an end of one wire from the brake box and an end of one wire from the harness into opposite ends of a wire connector. Crimp until snug.
14. To weather seal the connector, apply heat until its shrunk around the wires and cable.
 - Note: do steps 13-14 for each wire (3 total).
15. Connect the trailer to a vehicle and test that all the lights are working.
16. Reattach the gooseneck front access door back on.
17. Reattach the rivet door using new rivets and a rivet tool.
18. Remove the safety chain from the old outer tongue and attach to the new outer tongue.
19. Tighten any remaining hardware.

If you have questions, call Ben Sommers at 515.601.6521



OVERVIEW

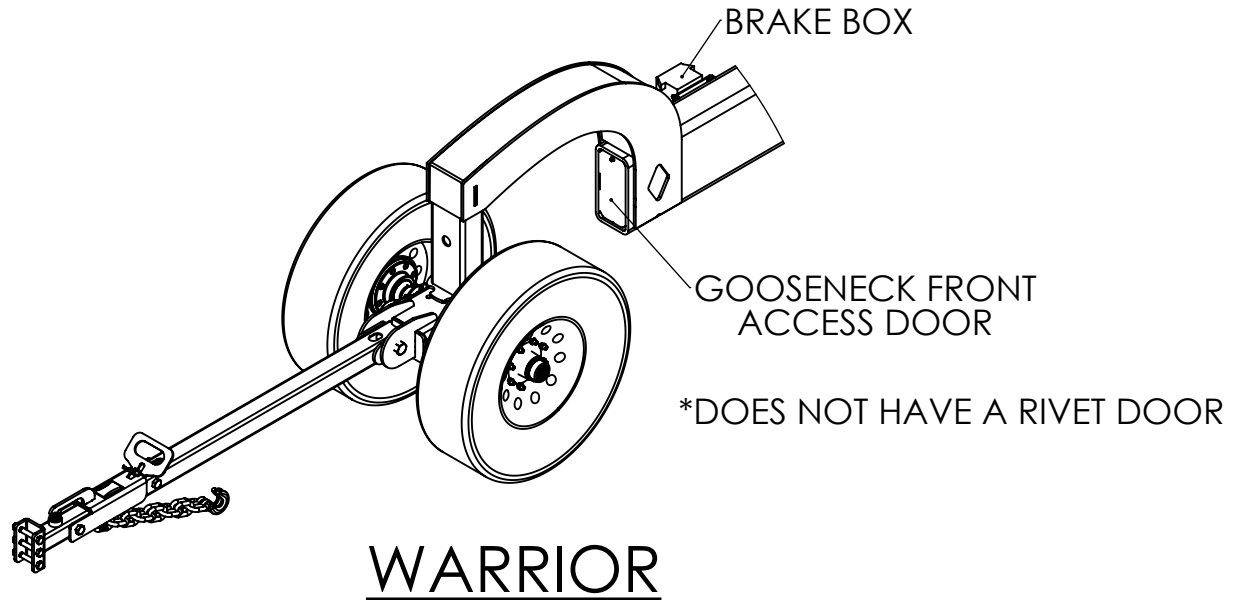
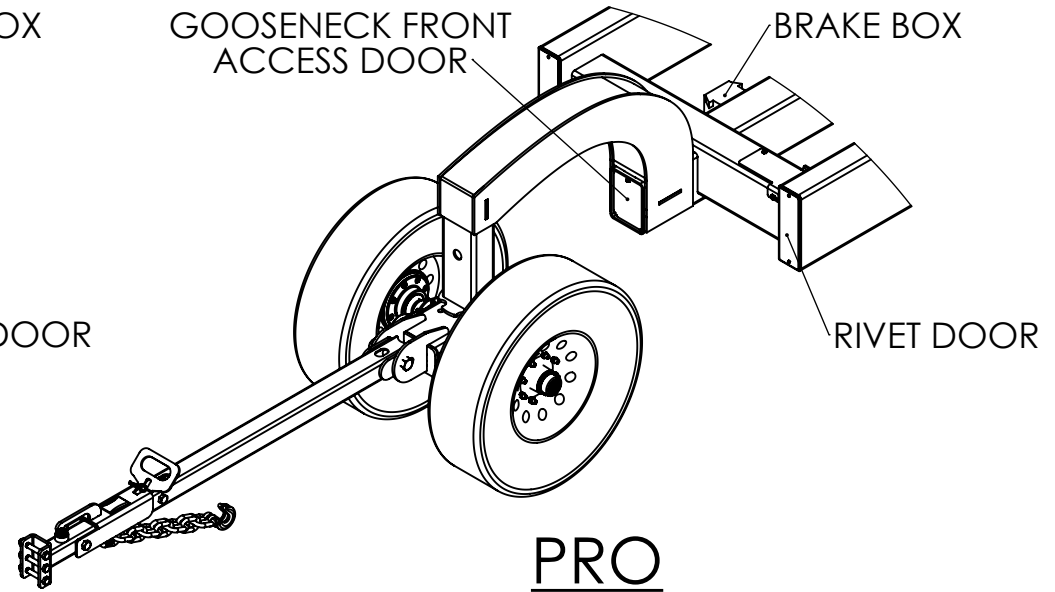
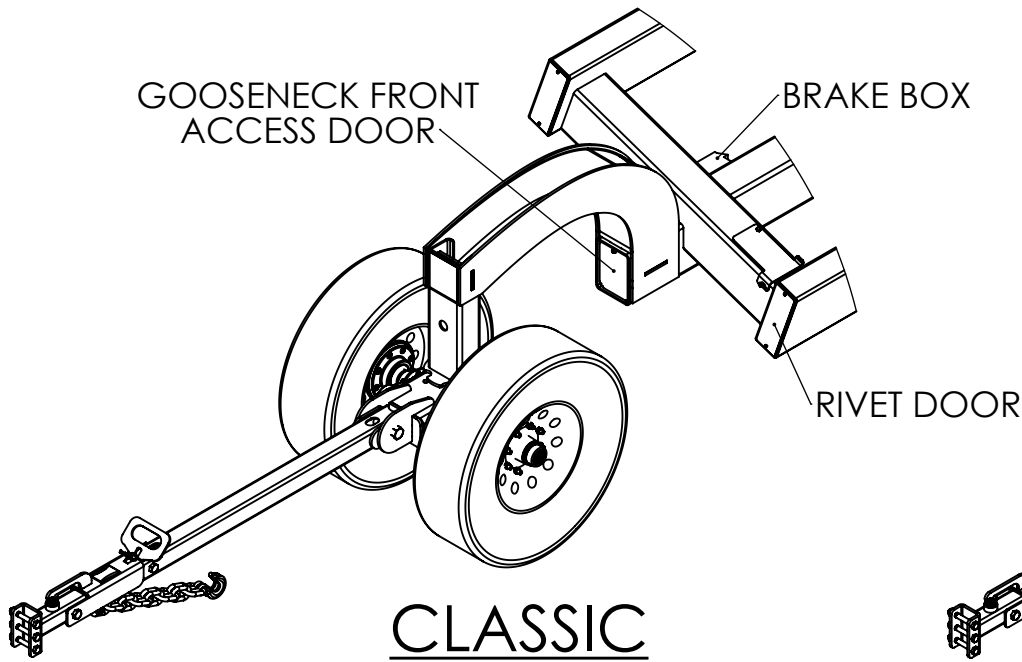

NOTES:
1. SOME COMPONENTS REMOVED FOR CLARITY.



STANDARD TONGUE

87-010000

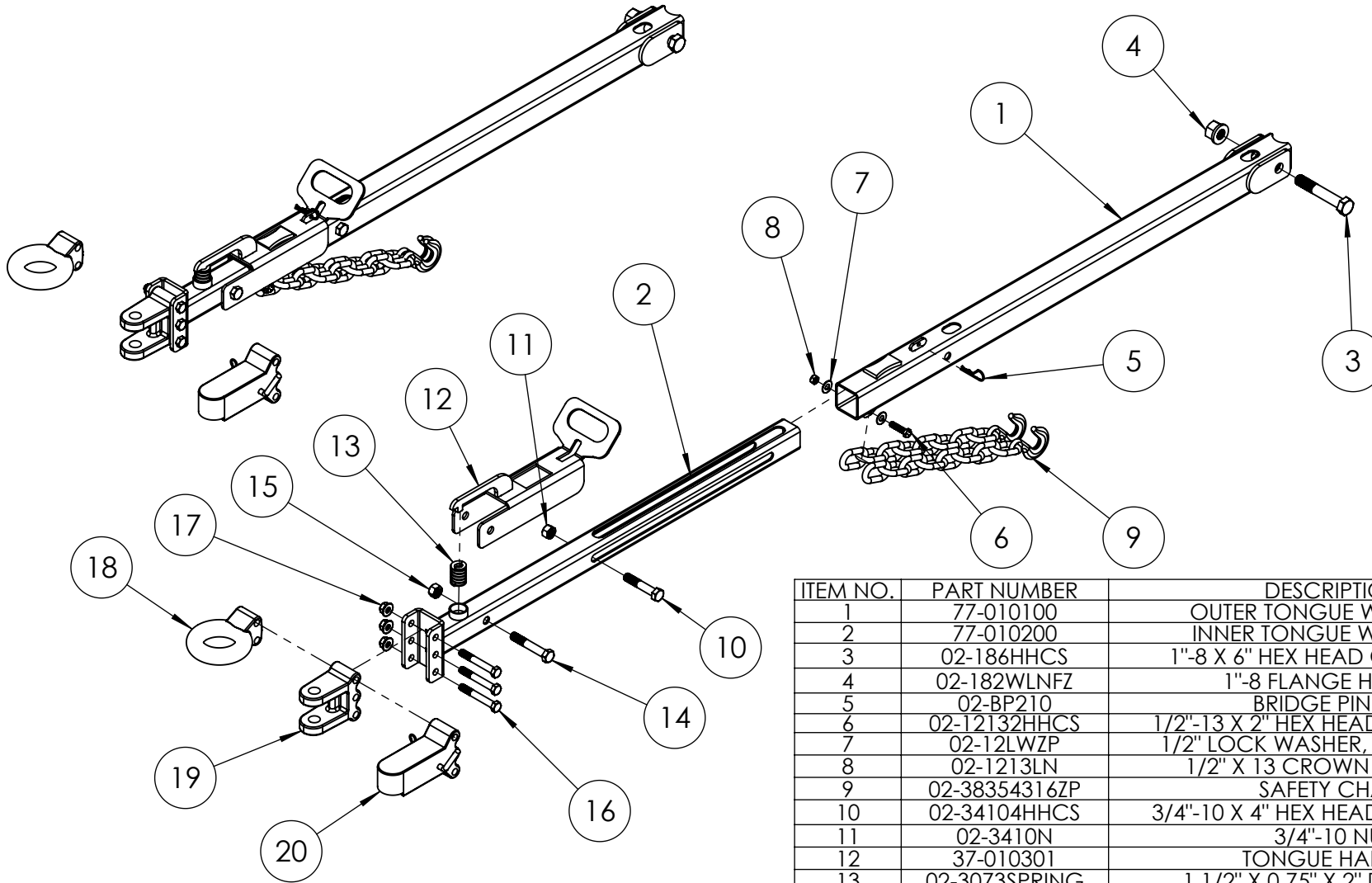

ITEM NO.	PART NUMBER	DESCRIPTION	QTY.
1	77-010100	OUTER TONGUE WELDMENT	1
2	77-010200	INNER TONGUE WELDMENT	1
3	02-186HHCS	1"-8 X 6" HEX HEAD CAP SCREW	1
4	02-182WLNZF	1"-8 FLANGE HEX NUT	1
5	02-BP210	BRIDGE PIN 210	1
6	02-12132HHCS	1/2"-13 X 2" HEX HEAD CAP SCREW	1
7	02-12LWZP	1/2" LOCK WASHER, ZINC PLATED	2
8	02-1213LN	1/2" X 13 CROWN LOCK NUT	1
9	02-38354316ZP	SAFETY CHAIN	2
10	02-34104HHCS	3/4"-10 X 4" HEX HEAD CAP SCREW	1
11	02-3410N	3/4"-10 NUT	1
12	37-010301	TONGUE HANDLE	1
13	02-3073SPRING	1 1/2" X 0.75" X 2" DIE SPRING	1
14	02-3410412HHCS	3/4"-10 X 4 1/2" HEX HEAD CAP SCREW	1
15	02-3410N	3/4"-10 NUT	1
16	02-5811412HHCS	5/8"-11 X 4 1/2" HEX HEAD CAP SCREW	3
17	02-5811CLNZP	5/8"-11 CROWN LOCK NUT, ZINC PLATED	3
18	02-16137	3" PINTLE EYE RING HITCH	1
19	02-07433800	CLEVIS HITCH WITH 1" HOLE	1
20	02-AC20	2 5/16" BALL COUPLER	1

NOTES:

1. THE CLEVIS HITCH, BALL COUPLER, AND PINTLE EYE RING HITCH ARE ALL INTERCHANGEABLE.



94" TONGUE EXTENSION

87-0104000

ITEM NO.	PART NUMBER	DESCRIPTION	QTY.
1	77-010400	OUTER TONGUE WELDMENT	1
2	77-010200	INNER TONGUE WELDMENT	1
3	02-186HHCS	1"-8 X 6" HEX HEAD CAP SCREW	1
4	02-182WLNFLZ	1"-8 FLANGE HEX NUT	1
5	02-BP210	BRIDGE PIN 210	1
6	02-12132HHCS	1/2"-13 X 2" HEX HEAD CAP SCREW	1
7	02-1213LWZP	1/2" LOCK WASHER, ZINC PLATED	2
8	02-1213LN	1/2"-13 CROWN LOCK NUT	1
9	02-38354316ZP	SAFETY CHAIN	2
10	02-34104HHCS	3/4"-10 X 4" HEX HEAD CAP SCREW	1
11	02-3410N	3/4"-10 NUT	1
12	37-010301	TONGUE HANDLE	1
13	02-3073SPRING	1 1/2" X 0.75" X 2" DIE SPRING	1
14	02-3410412HHCS	3/4"-10 X 4 1/2" HEX HEAD CAP SCREW	1
15	02-3410N	3/4"-10 NUT	1
16	02-5811412HHCS	5/8"-11 X 4 1/2" HEX HEAD CAP SCREW	3
17	02-5811CLNZP	5/8"-11 CROWN LOCK NUT, ZINC PLATED	3
18	02-16137	3" PINTLE EYE RING HITCH	1
19	02-07433800	CLEVIS HITCH WITH 1" HOLE	1
20	02-AC20	2 5/16" BALL COUPLER	1

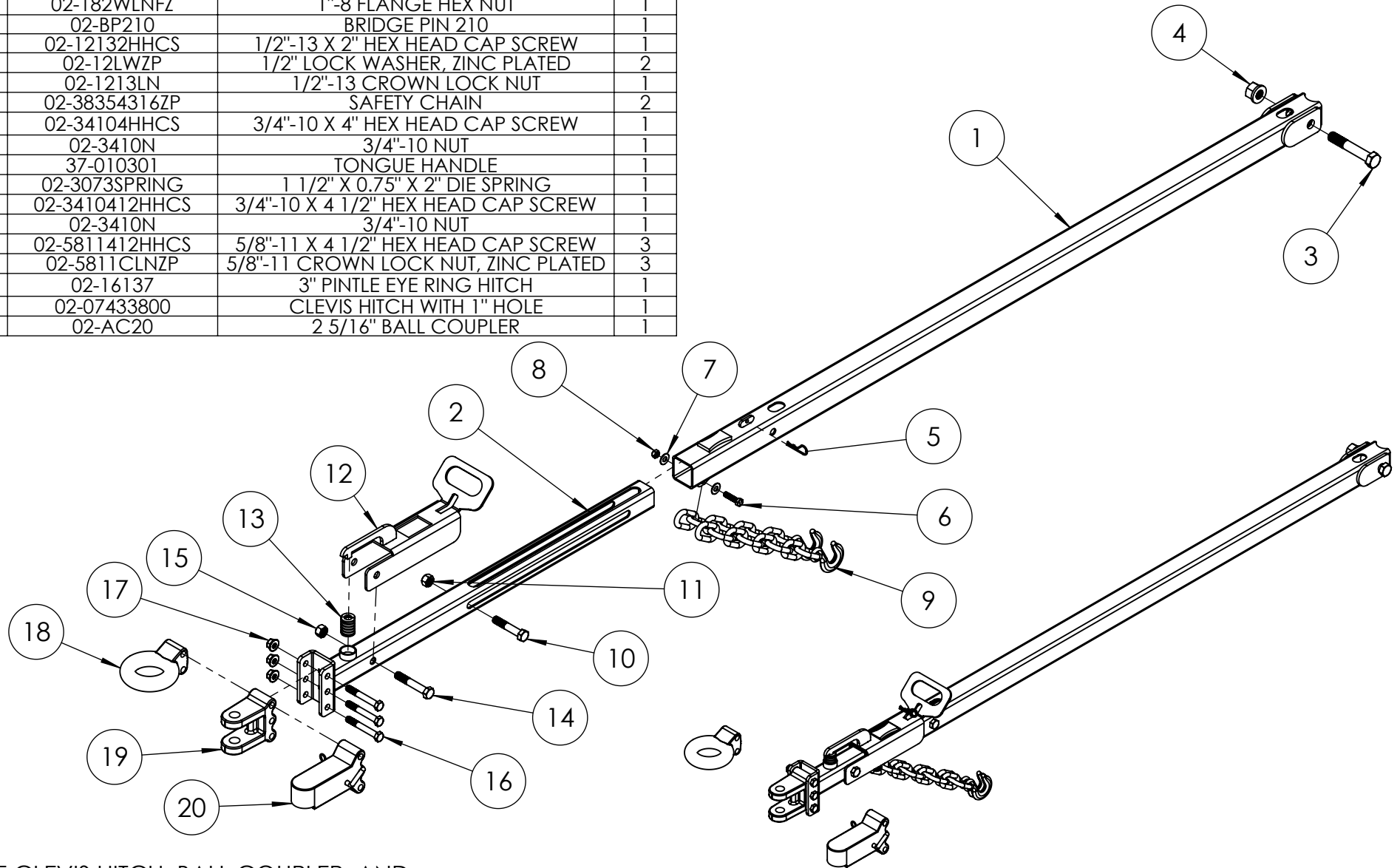

NOTES:

1. THE CLEVIS HITCH, BALL COUPLER, AND PINTLE EYE RING HITCH ARE ALL INTERCHANGEABLE.

